



# Operation Manual

Solenoid Valve

PRODUCT NAME

*SQ Series*  
*(Pilot Valve V100)*

MODEL / Series / Product Number

**SMC Corporation**

# Contents

Safety Instructions .....	2,3
Precautions on Design .....	4,5
Selection .....	4,5
Mounting .....	5
Piping .....	5
Wiring .....	6
Lubrication .....	6
Air Supply .....	6
Operating Environment .....	7
Maintenance .....	7
Specific Product Precautions .....	8 to 10
Valve construction .....	11 to 14
Trouble shooting .....	15,16



# Safety Instructions

These safety instructions are intended to prevent hazardous situations and/or equipment damage. These instructions indicate the level of potential hazard with the labels of "Caution," "Warning" or "Danger." They are all important notes for safety and must be followed in addition to International Standards (ISO/IEC)\*1), and other safety regulations.

- \*1) ISO 4414: Pneumatic fluid power -- General rules relating to systems  
ISO 4413: Hydraulic fluid power -- General rules relating to systems  
IEC 60204-1: Safety of machinery -- Electrical equipment of machines (Part 1: General requirements)  
ISO 10218-1992: Manipulating industrial robots -- Safety



## Caution

**Caution** indicates a hazard with a low level of risk which, if not avoided, could result in minor or moderate injury.



## Warning

**Warning** indicates a hazard with a medium level of risk which, if not avoided, could result in death or serious injury.



## Danger

**Danger** indicates a hazard with a high level of risk which, if not avoided, will result in death or serious injury.

## Warning

### 1. The compatibility of the product is the responsibility of the person who designs the equipment or decides its specifications.

Since the product specified here is used under various operating conditions, its compatibility with specific equipment must be decided by the person who designs the equipment or decides its specifications based on necessary analysis and test results.

The expected performance and safety assurance of the equipment will be the responsibility of the person who has determined its compatibility with the product.

This person should also continuously review all specifications of the product referring to its latest catalog information, with a view to giving due consideration to any possibility of equipment failure when configuring the equipment.

### 2. Only personnel with appropriate training should operate machinery and equipment.

The product specified here may become unsafe if handled incorrectly.

The assembly, operation and maintenance of machines or equipment including our products must be performed by an operator who is appropriately trained and experienced.

### 3. Do not service or attempt to remove product and machinery/equipment until safety is confirmed.

1. The inspection and maintenance of machinery/equipment should only be performed after measures to prevent falling or runaway of the driven objects have been confirmed.

2. When the product is to be removed, confirm that the safety measures as mentioned above are implemented and the power from any appropriate source is cut, and read and understand the specific product precautions of all relevant products carefully.

3. Before machinery/equipment is restarted, take measures to prevent unexpected operation and malfunction.

### 4. Contact SMC beforehand and take special consideration of safety measures if the product is to be used in any of the following conditions.

1. Conditions and environments outside of the given specifications, or use outdoors or in a place exposed to direct sunlight.

2. Installation on equipment in conjunction with atomic energy, railways, air navigation, space, shipping, vehicles, military, medical treatment, combustion and recreation, or equipment in contact with food and beverages, emergency stop circuits, clutch and brake circuits in press applications, safety equipment or other applications unsuitable for the standard specifications described in the product catalog.

3. An application which could have negative effects on people, property, or animals requiring special safety analysis.

4. Use in an interlock circuit, which requires the provision of double interlock for possible failure by using a mechanical protective function, and periodical checks to confirm proper operation.



# Safety Instructions

## Caution

**The product is provided for use in manufacturing industries.**

The product herein described is basically provided for peaceful use in manufacturing industries.

If considering using the product in other industries, consult SMC beforehand and exchange specifications or a contract if necessary.

If anything is unclear, contact your nearest sales branch.

## Limited warranty and Disclaimer/Compliance Requirements

The product used is subject to the following “Limited warranty and Disclaimer” and “Compliance Requirements”.

Read and accept them before using the product.

### Limited warranty and Disclaimer

**1.The warranty period of the product is 1 year in service or 1.5 years after the product is delivered.\*2)**

**Also, the product may have specified durability, running distance or replacement parts. Please consult your nearest sales branch.**

**2.For any failure or damage reported within the warranty period which is clearly our responsibility, a replacement product or necessary parts will be provided.**

**This limited warranty applies only to our product independently, and not to any other damage incurred due to the failure of the product.**

**3.Prior to using SMC products, please read and understand the warranty terms and disclaimers noted in the specified catalog for the particular products.**

**\*2) Vacuum pads are excluded from this 1 year warranty.**

**A vacuum pad is a consumable part, so it is warranted for a year after it is delivered.**

**Also, even within the warranty period, the wear of a product due to the use of the vacuum pad or failure due to the deterioration of rubber material are not covered by the limited warranty.**

### Compliance Requirements

**1.The use of SMC products with production equipment for the manufacture of weapons of mass destruction (WMD) or any other weapon is strictly prohibited.**

**2.The exports of SMC products or technology from one country to another are governed by the relevant security laws and regulation of the countries involved in the transaction. Prior to the shipment of a SMC product to another country, assure that all local rules governing that export are known and followed.**

## Caution

**SMC products are not intended for use as instruments for legal metrology.**

Measurement instruments that SMC manufactures or sells have not been qualified by type approval tests relevant to the metrology (measurement) laws of each country. Therefore, SMC products cannot be used for business or certification ordained by the metrology (measurement) laws of each country.



## SQ Series

# Precautions for 5 Port Solenoid Valve 1

Be sure to read before handling. Refer to main text for detailed precautions on every series.

### Design / Selection

#### Warning

##### 1. Confirm the specifications

Products represented in this catalog are designed only for use in compressed air systems (including vacuum). Do not operate at pressures, temperatures, etc., beyond the range of specifications, as this can cause damage or malfunction. (Refer to the specifications.) Please contact SMC when using a fluid other than compressed air (including vacuum). We do not guarantee against any damage if the product is used outside of the specification range.

##### 2. Actuator drive.

When an actuator, such as a cylinder, is to be driven using a valve, take appropriate measures (such as the installation of a cover or the restricting of access to the product) to prevent potential danger caused by actuator operation.

##### 3. Intermediate stops.

For the 3-position closed center, it is difficult to make the piston stop at the required position accurately due to the compressibility of air.

Furthermore, since valves and cylinders are not guaranteed for zero air leakage, it may not be possible to hold a stopped position for an extended period of time.

Please contact SMC if it is necessary to hold a stopped position for an extended period of time.

##### 4. Effect of back pressure when using a manifold.

Use caution when valves are used on a manifold because actuators may malfunction due to back pressure.

Especially when using a 3-position exhaust center valve or a single acting cylinder, take appropriate measures to prevent malfunction by using it with an individual EXH spacer assembly, a back pressure check valve, or an individual exhaust manifold. Also, since the SQ1000 4-position dual 3-port valve is a 4-port valve specification (R1 and R2 are common), one back pressure check valve can be installed. As a result, back pressure from valves in other stations can be prevented, but back pressure inside this valve cannot be prevented.

##### 5. Holding pressure (including vacuum)

Since valves are subject to air leakage, they cannot be used for applications such as holding pressure (including vacuum) in a pressure vessel.

##### 6. Not suitable for use as an emergency shutoff valve, etc.

The valves listed in this catalog are not designed for safety applications such as an emergency shutoff valve. If the valves are used in such applications, additional safety measures should be adopted.

##### 7. Release of residual pressure

For maintenance and inspection purposes install a system for releasing residual pressure. Especially in the case of the 3-position closed center valve, ensure that the residual pressure between the valve and the cylinder is released.

##### 8. Operation in a vacuum condition

When a valve is used for switching a vacuum, take measures to install a suction filter or similar to prevent external dust or other foreign matter from entering inside the valve.

In addition, at the time of vacuum adsorption, be sure to supply a constant supply of vacuum. Failure to do so may result in foreign matter sticking to the adsorption pad or air leakage, causing the workpiece to drop.

##### 9. Regarding vacuum switch valves and vacuum release valves

If a non-vacuum valve is installed in the middle of a piping system that contains a vacuum, the vacuum condition will not be maintained. Use a valve designed for use under vacuum conditions.

##### 10. Double solenoid type

When using the double solenoid type for the first time, actuators may travel in an unexpected direction depending on the switching position of the valve. Implement measures to prevent any danger from occurring when operating the actuator.

##### 11. Ventilation

Provide ventilation when using a valve in a confined area, such as in a closed control panel. For example, install a ventilation opening, etc., in order to prevent pressure from increasing inside of the confined area and to release the heat generated by the valve.

##### 12. Extended periods of continuous energization

● If a valve will be continuously energized for an extended period of time, the temperature of the valve will increase due to the heat generated by the coil assembly. This will likely adversely affect the performance of the valve and any nearby peripheral equipment. Therefore, if the valve is to be energized for periods of longer than 30 minutes at a time or if during the hours of operation the energized period per day is longer than the de-energized period, we advise using a valve with specifications listed below.

- Pilot operated: A 0.4 W or lower valve, such as the SY series, or a valve with a power-saving circuit
- Direct operated: A continuous duty type valve such as the VK series or the VT series

If conflicting instructions are given in the "Specific Product Precautions" or on the "How to Order Valves" page, give them priority.

##### 13. Do not disassemble the product or make any modifications, including additional machining.

Doing so may cause human injury and/or an accident.

#### Caution

##### 1. Precautions for 2-position double solenoid valves

If a double solenoid valve is operated with momentary energization, it should be energized for at least 0.1 seconds. However, depending on the piping conditions, the cylinder may malfunction even when the double solenoid valve is energized for 0.1 seconds or longer. In this case, energize the double solenoid valve until the cylinder is exhausted completely.

##### 2. Leakage voltage

Take note that the leakage voltage will increase when a resistor is used in parallel with a switching element or when a C-R circuit (surge voltage suppressor) is used for protecting a switching device because of the leakage voltage passing through the C-R circuit. The suppressor residual leakage voltage should be as follows.

 3% or less of the rated voltage

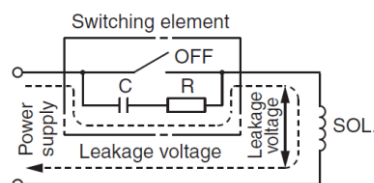



# Precautions for 5 Port Solenoid Valve 2

Be sure to read before handling. Refer to main text for detailed precautions on every series.

### Design / Selection

#### Caution

#### 3. Surge voltage suppressor

- 1) The surge voltage suppressor built into the valve is intended to protect the output contacts so that the surge generated inside valve does not adversely affect the output contacts. Therefore, if an overvoltage or overcurrent is received from an external peripheral device, the surge voltage protection element inside the valve is overloaded, causing the element to break. In the worst case, the breakage causes the electric circuit to enter short-circuit status. If energizing continues while in this state, a large current flows. This may cause secondary damage to the output circuit, external peripheral device, or valve, and may also cause a fire. So, take appropriate protective measures, such as the installation of an overcurrent protection circuit in the power supply or a drive circuit to maintain a sufficient level of safety.
- 2) If a surge protection circuit contains nonstandard diodes, such as Zener diodes or varistor, a residual voltage that is in proportion to the protective circuit and the rated voltage will remain. Therefore, take into consideration the surge voltage protection of the controller.  
In the case of diodes, the residual voltage is approximately 1V.

#### 4. Operation in low temperature conditions

It is possible to operate a valve in extreme temperatures, as low as  $-10^{\circ}\text{C}$ . Take appropriate measures to avoid the freezing of drainage, moisture, etc., in low temperatures.

#### 5. Operation for air blowing

When using a solenoid valve for air blowing, use an external pilot type.

Use caution because the pressure drop caused by the air blowing can have an effect on the internal pilot type valve when internal pilot type valves and external pilot type valves are used on the same manifold.

Additionally, when compressed air within the pressure range of the established specifications is supplied to the external pilot type valve's port, and a double solenoid valve is used for air blowing, the solenoids should be energized when air is being blown.

#### 6. Mounting orientation

Rubber seal : The mounting orientation is universal.

Metal seal : The mounting orientation of a single solenoid is universal. No specific orientation is necessary.  
When installing a double solenoid or a 3-position configuration, mount the valve so that the spool valve is horizontal.

#### 7. Initial lubrication of main valve

The following initial lubricant has already been applied to the main valve.

- Rubber seal, spool valve: Grease

Please consult with SMC, as there are some standard valve products that use fluorine grease for food processing equipment (NSF H-1).

- Metal seal, spool valve: Turbine oil

Turbine oil is applied to the spool valve of the metal seal type. Therefore, turbine oil may seep out when a new product is delivered or while the valve is in storage.

### Mounting

#### Warning

#### 1. Operation Manual

Install the products and operate them only after reading the operation manual carefully and understanding its contents. Also, keep the manual where it can be referred to as necessary.

#### 2. Ensure sufficient space for maintenance activities.

When installing the products, allow access for maintenance and inspection.

#### 3. Tighten threads with the proper tightening torque.

When installing the products, follow the listed torque specifications.

#### 4. If air leakage increases or equipment does not operate properly, stop operation.

Check mounting conditions when air and power supplies are connected. Initial function and leakage tests should be performed after installation.

#### 5. Painting and coating

Warnings or specifications printed on or affixed to the product should not be erased, removed, or covered up.

Please consult with SMC before applying paint to resinous parts, as this may have an adverse effect due to the solvent in the paint.

### Piping

#### Caution

#### 1. Refer to the Fittings and Tubing Precautions for handling One-touch fittings.

#### 2. Preparation before piping.

Before piping is connected, it should be thoroughly blown out with air (flushing) or washed to remove chips, cutting oil, and other debris from inside the pipe.

#### 3. Winding of sealant tape

When screwing piping or fittings into ports, ensure that chips from the pipe threads or sealing material do not enter the piping. Also, if sealant tape is used, leave 1 thread ridge exposed at the end of the threads.

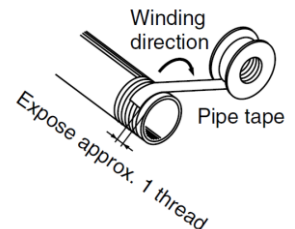

#### 4. Closed center types

For the closed center, check the piping to prevent air leakage from the piping between the valve and the cylinder.

#### 5. Connection of piping and fittings

When screwing fittings into valves, tighten as follows.

- (1) Follow the procedures below when installing an SMC fitting etc.

##### •M5 types

After tightening the fitting by hand, use a wrench to tighten the fitting an additional approximately 1/6 to 1/4 turn. As a reference value, tightening torque is 1 to 1.5 N·m.

- (2) Follow the procedures of the manufacturer when fittings other than SMC are used.

#### 6. Piping to products

When piping to a product, to avoid mistakes regarding the supply port, etc.



## SQ Series

# Precautions for 5 Port Solenoid Valve 3

Be sure to read before handling. Refer to main text for detailed precautions on every series.

### Wiring

#### Warning

1. **The solenoid valve is an electrical product. For safety, install an appropriate fuse and circuit breaker before use.**

#### Caution

1. **Polarity.**  
When connecting power to a solenoid valve with a DC specification and equipped with a light or surge voltage suppressor, check for polarity.
2. **Applied voltage**  
When electric power is connected to a solenoid valve, be careful to apply the proper voltage. Improper voltage may cause malfunction or coil damage.
3. **Check the connections.**  
Check if the connections are correct after completing all wiring.
4. **External force applied to the lead wire**  
If an excessive force is applied to the lead wire, this may cause faulty wiring. Take appropriate measures so that a force of 30 N or more is not applied to the lead wire.  
When instructions are given in the Specific Product Precautions, follow these specifications.

### Lubrication

#### Warning

##### 1. Lubrication

###### [Rubber seal]

- 1) All valves have been lubricated for life by the manufacturer and therefore, do not require lubrication while in service.
- 2) If a lubricant is used in the system, use class 1 turbine oil (no additives), ISO VG32. For details about lubricant manufacturers' brands, refer to the SMC website. Additionally, please contact SMC for details about class 2 turbine oil (with additives) ISO VG32. Once lubricant is utilized within the system, since the original lubricant applied within the product during manufacturing will be washed away, please continue to supply lubrication to the system. Without continued lubrication, malfunctions could occur. If turbine oil is used, refer to the Safety Data Sheet (MSDS) of the oil.

###### [Metal seal]

- 1) These valves can be used without lubrication.
- 2) If a lubricant is used in the system, use class 1 turbine oil (no additive), ISO VG32. Refer to SMC's website for details about each manufacturer's brand name of class 1 turbine oil (no additive) ISO VG32. Additionally, please contact SMC for details about class 2 turbine oil (with additives) ISO VG32.

##### 2. Lubrication amount

If the lubrication amount is excessive, the oil may accumulate inside the pilot valve, causing malfunction or response delay. So, do not apply a large amount of oil. When a large amount of oil on the pilot valve side in the non-lube state. This prevents the accumulation of oil inside the pilot valve.

### Air Supply

#### Warning

##### 1. Type of fluids

Please consult with SMC when using the product in applications other than compressed air.

##### 2. When there is a large amount of drainage.

Compressed air containing a large amount of drainage can cause malfunction of pneumatic equipment. An air dryer or water separator should be installed upstream from filters.

##### 3. Drain flushing

If condensation in the drain bowl is not emptied on a regular basis, the bowl will overflow and This may cause malfunction of pneumatic equipment. If the drain bowl is difficult to check and remove, installation of a drain bowl with an auto drain option is recommended.

For compressed air quality, refer to SMC's Best Pneumatics catalog.

##### 4. Use clean air.

Do not use compressed air that contains chemicals, synthetic oils including organic solvents, salt or corrosive gases, etc., as it can cause damage or malfunction.

#### Caution

1. **When extremely dry air is used as the fluid, degradation of the lubrication properties inside the equipment may occur, resulting in reduced reliability (or reduced service life) of the equipment. Please consult with SMC.**

##### 2. Install an air filter.

Install an air filter upstream near the valve. Select an air filter with a filtration size of 5 μm or smaller.

##### 3. Take measures to ensure air quality, such as by installing an aftercooler, air dryer, or water separator.

Compressed air that contains a large amount of drainage can cause malfunction of pneumatic equipment such as valves. Therefore, take appropriate measures to ensure air quality, such as by providing an aftercooler, air dryer, or water separator.

##### 4. If excessive carbon powder is seen, install a mist separator on the upstream side of the valve.

If excessive carbon dust is generated by the compressor, it may adhere to the inside of the valve and cause it to malfunction.

For compressed air quality, refer to SMC's Best Pneumatics catalog.





## Precautions for 5 Port Solenoid Valve 4

Be sure to read before handling. Refer to main text for detailed precautions on every series.

### Operating Environment

#### Warning

1. Do not use in an atmosphere having corrosive gases, chemicals, sea water, water, water steam, or where there is direct contact with any of these.
2. Do not use in an environment where flammable gas or explosive gas exists. Usage may cause a fire or explosion. The products do not have an explosion proof construction.
3. Do not use in a place subject to heavy vibration and/or shock.
4. The valve should not be exposed to prolonged sunlight. Use a protective cover. Note that the valve is not for outdoor use.
5. Remove any sources of excessive heat.
6. If it is used in an environment where there is possible contact with oil, weld spatter, etc., exercise preventive measures.
7. When the solenoid valve is mounted in a control panel or it's energized for a long period of time, make sure the ambient temperature is within the specifications of the valve.

#### Caution

1. **Temperature of ambient environment**  
Use the valve within the range of the ambient temperature specification of each valve. In addition, pay attention when using the valve in environments where the temperature changes drastically.
2. **Humidity of ambient environment**
  - When using the valve in environments with low humidity, take measures to prevent static.
  - If the humidity rises, take measures to prevent the adhesion of water droplets on the valve.

### Maintenance

#### Warning

1. **Perform maintenance inspection according to the procedures indicated in the operation manual.**  
If handled improperly, human injury and/or malfunction or damage of machinery and equipment may occur.
2. **Removal of equipment, and supply/exhaust of compressed air**  
Before components are removed, first confirm that measures are in place to prevent workpieces from dropping, run-away equipment, etc. Then, cut off the supply air and electric power, and exhaust all air pressure from the system using the residual pressure release function.  
For the 3-position closed center, exhaust the residual pressure between the valve and the cylinder.  
When the equipment is operated after remounting or replacement, first confirm that measures are in place to prevent the lurching of actuators, etc. Then, confirm that the equipment is operating normally.  
In particular, when a 2-position double solenoid valve is used, releasing residual pressure rapidly may cause the spool valve to malfunction, depending on the piping conditions, or the connected actuator to operate.
3. **Low frequency operation**  
Valves should be operated at least once every 30 days to prevent malfunction. (Use caution regarding the air supply.)
4. **Manual override**  
When a manual override is operated, connected equipment will be actuated. Operate only after safety is confirmed.
5. **If the volume of air leakage increases or the valve does not operate normally, do not use the valve. Perform periodic maintenance on the valve to confirm the operating condition and check for any air leakage.**

#### Caution

1. **Drain flushing**  
Remove drainage from the air filters regularly.
2. **Lubrication**  
In the case of rubber seals, once lubrication has been started, it must be continued. Use class 1 turbine oil (with no additive), VG32. If other lubricant oil is used, it may cause malfunction. Please contact SMC for suggested class 2 turbine oil (with additive), VG32.
3. **Manual override operation**  
When switching a double solenoid valve via the manual override operation, instantaneous operation may cause the malfunction of the cylinder. It is recommended that the manual override be held until the cylinder reaches the stroke end position.





## SQ series

# Specific Product Precautions 1

Be sure to read this before handling.

### Manual override

#### Warning

Use to switch the main valve.

#### Push Type (Tool Required)

Push down on the manual override button with a small screwdriver until it stops.

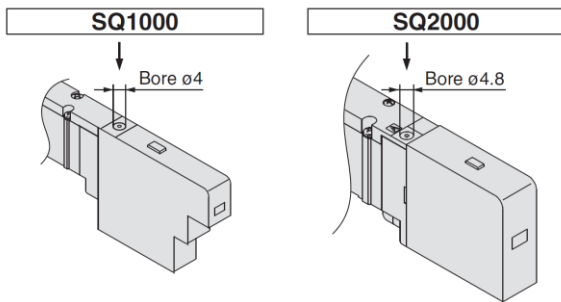

#### Locking type (Tool required)

Push down completely on the manual override button with a small screwdriver. While down, turn clockwise 90° to lock it. Turn it counterclockwise to release it.

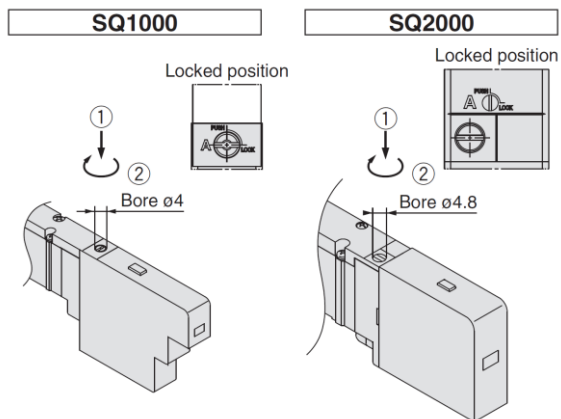

#### Slide locking type (Manual Type) (SQ2000 only)

The manual override is locked by sliding it all the way to the pilot valve side (ON side) with a small flat head screwdriver or fingers.

Slide it to the fitting side (OFF side) to release it.

In addition, it can also be used as a push type by using a screwdriver, etc. of  $\phi 2$  or less.

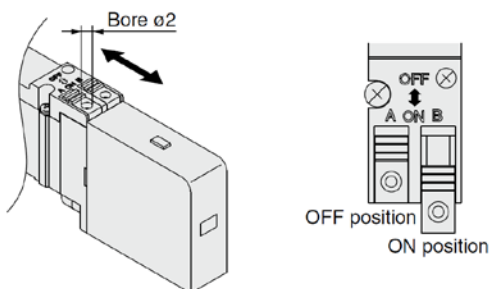

### Light/Surge voltage suppressor

#### Caution

Indicator lights are all positioned on one side for both single solenoid and double solenoid types.

For double, 3 positions, 4 position dual 3 port types, 2 colors are used to indicate the energization of A side or B side.

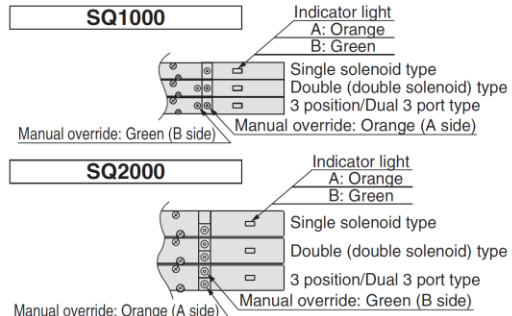

#### • Single solenoid type (SQ1000/2000)

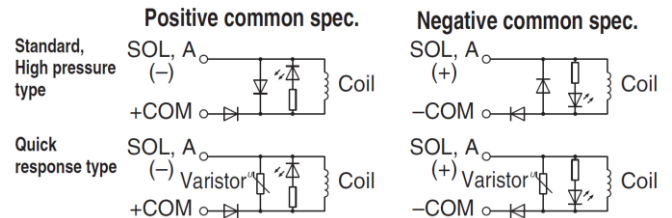

Note) With quick response type, approximately -40 V of coil surge voltage is generated when the valve is switched OFF.

#### • Double solenoid type (SQ1000/2000)

#### • 3 position type (SQ1000/2000)

#### • 4 position dual 3 port type (SQ1000/2000)

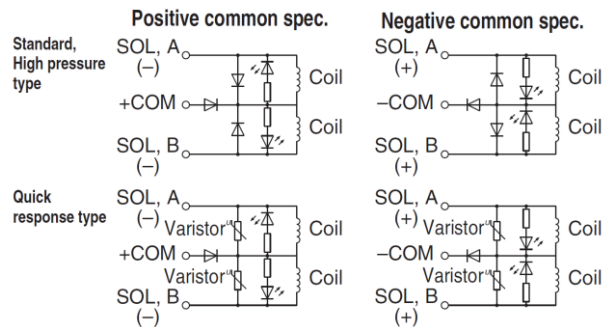

Note) With quick response type, approximately -40 V of coil surge voltage is generated when the valve is switched OFF.

### Continuous Duty

#### Caution

If a valve is energized continuously for a long period of time, the rise in temperature due to heat-up of the coil assembly may cause a decline in solenoid valve performance, reduce service life, or have adverse effects on peripheral equipment. When the valve is continuously energized, use the standard type (0.4 W) at ambient temperature of 40°C or less with proper heat radiation. In particular, if three or more adjacent stations on the manifold are energized simultaneously for extended periods of time or if the valves on A side and B side of the dual 3 port valve are energized simultaneously for a long period of time, take special care as the temperature rise will be greater.



## SQ series

# Specific Product Precautions 2

Be sure to read this before handling.

### Mounting and removal of valve

#### Caution

#### Mounting

- Insert the hook of the valve into the bracket on the manifold block, then push the valve down into place and tighten the mounting screw.
- Tighten the screw with specified tightening torque shown below.

<b>SQ1000</b>	0.17 to 0.23N·m
<b>SQ2000</b>	0.25 to 0.35N·m

- When pushing the valve down, press it on the area near the manual override. Be careful not to push the solenoid cover.

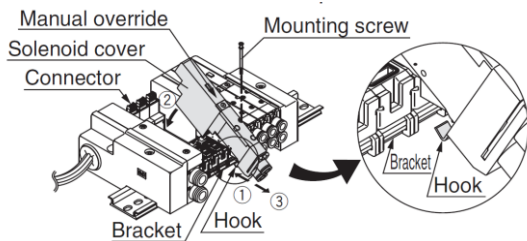

#### Removing

- Loosen the valve mounting screw, lift the valve from the solenoid cover side and remove it by sliding it in the direction of arrow 3.

If it is difficult to loosen the screw, loosen it while pressing the valve gently on the area near the manual override.

### Mounting and Removal of Manifold with DIN Rail

#### Caution

#### Removing Manifold from DIN Rail

1. Loosen the end plate clamping screws on both sides until they turn freely. (The screws do not come out.)
2. Remove the manifold from the DIN rail by lifting it from the solenoid cover side.

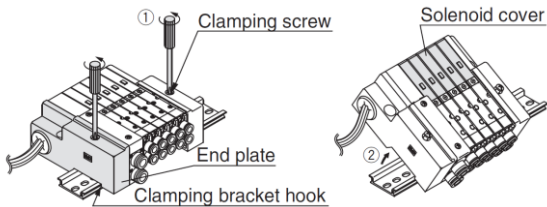

When a manifold contains a large number of stations and it is difficult to remove all at once, separate the manifold into several sections before removing it.

#### Mounting Manifold to DIN rail

The procedure is the reverse of that above. After tightening the clamping screw on one side, push on the opposite end plate so that there are no gaps between the manifold blocks and then tighten the other clamping screw.

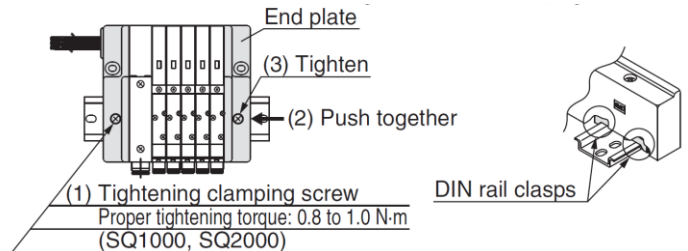

Confirm that the DIN rail clasps are securely hooked into the DIN rail.

### Replacement of Cylinder Port Fittings

#### Caution

The cylinder port fittings are a cassette for easy replacement. Fittings are secured with a clip that is inserted from the top side of the valve. Remove the clip with a flat head screwdriver, etc., to replace the fittings.

To mount a fitting, insert the fitting assembly until it stops and reinsert the clip to its designated position.

Applicable tube O.D. (mm)	Product number of Fitting assembly	
	SQ1000	SQ2000
3.2	VVQ1000-50A-C3	-
4	VVQ1000-50A-C4	VVQ1000-51A-C4
6	VVQ1000-50A-C6	VVQ1000-51A-C6
8	-	VVQ1000-51A-C8

\*Part numbers above are for one fitting; however, order them in 10 piece units.

#### Caution

Use caution that O-rings must be free from scratches and dust. Otherwise, air leakage may result.

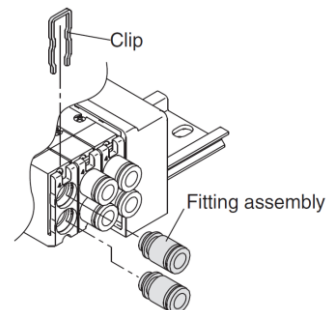



# SQ series Specific Product Precautions 3

Be sure to read this before handling.

## Built-in Silencer Replacement Element

### Caution

A filter element is built into the manifold base end plate. When the element becomes dirty and clogged, this will cause trouble such as a drop in the cylinder speed, etc. Therefore, replace the element regularly.

#### Element part no.

Type	Element part no.	
	SQ1000	SQ2000
Built-in silencer direct exhaust (-S)	SSQ1000-SE	SSQ2000-SE

\* Part numbers above are for a set of ten elements.

To replace an element, remove the cover on the top side of the end plate and remove the old element with a flat head screwdriver, etc.

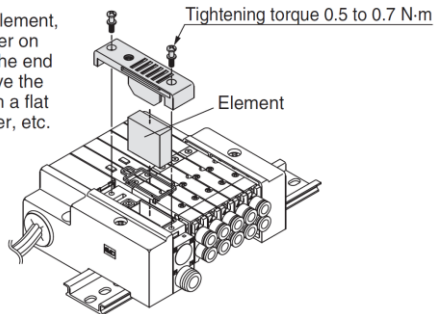

## How to Calculate Flow Rate

### Calculation of Flow Rate

When

$$\frac{P_2 + 0.1}{P_1 + 0.1} \leq b, \text{ choked flow}$$

$$Q = 600 \times C (P_1 + 0.1) \sqrt{\frac{293}{273 + t}} \dots\dots\dots(1)$$

When

$$\frac{P_2 + 0.1}{P_1 + 0.1} > b, \text{ subsonic flow}$$

$$Q = 600 \times C (P_1 + 0.1) \sqrt{1 - \left[ \frac{P_2 + 0.1}{P_1 + 0.1} - b \right]^2} \sqrt{\frac{293}{273 + t}} \dots\dots\dots(2)$$

Q : Air flow [dm<sup>3</sup>/min(ANR)] and dm<sup>3</sup> of unit SI can be shown in litter (ℓ)

$$1 \text{ dm}^3 = 1 \text{ ℓ}$$

C : Sonic conductance [dm<sup>3</sup>/(s·bar)]

b : Critical pressure ratio [-]

P1: Upstream pressure[MPa]

P2: Downstream pressure[MPa]

t: Temp. (°C)

Please refer to the energy saving program of SMC for details.

# SQ1000 Series

## Construction: SQ1000 Series Plug-in Type Main Parts and Pilot Valve Assembly

**Metal seal type**  
Single: SQ1130

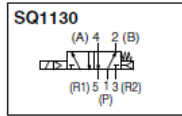
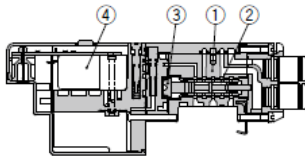

**Rubber seal type**  
Single: SQ1131

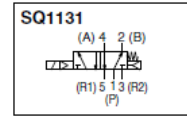
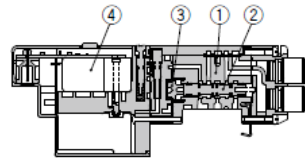

**Double: SQ1230D**

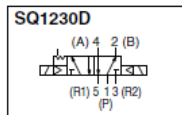
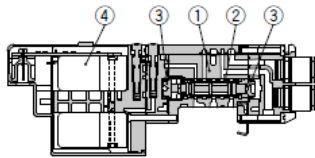

**Double: SQ1231D**

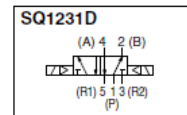
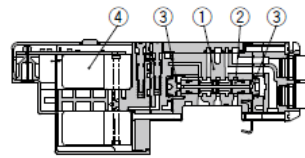

**3 position: SQ1430**

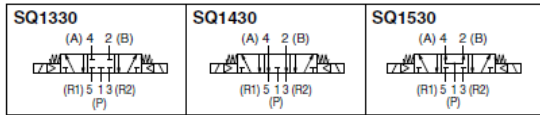
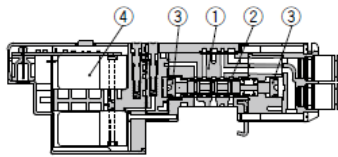

**3 position: SQ1531**

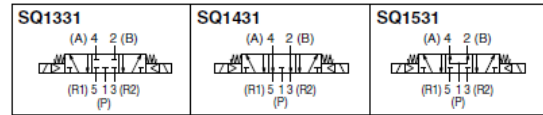
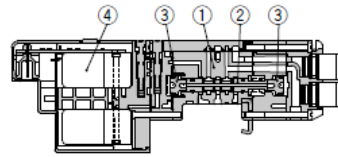

### Component Parts

No.	Description	Material
1	Body	Zinc die-casted
2	Spool/Sleeve	Stainless steel (Metal seal)
	Spool	Aluminum (Rubber seal)
3	Piston	Resin
4	Pilot valve assembly (Refer to the below.)	—

### Pilot valve assembly

V112 □ - □

#### Coil voltage

5	24 VDC
6	12 VDC

#### Function

Symbol	Specifications	DC
Nil	Standard type	(0.4 W) ○
B	Quick response type	(0.95 W) ○
K	High pressure type (1.0 MPa)	(0.95 W) ○

Note) Common to single solenoid and double solenoid

**Dual 3 port valve: SQ1<sup>A</sup><sub>B</sub>31**

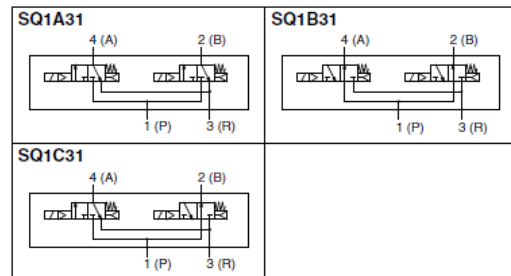
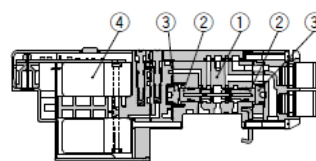

# Plug-in Unit **SQ2000 Series**

## Construction: SQ2000 Series Plug-in Type Main Parts and Pilot Valve Assembly

**Metal seal type**  
Single: SQ2130

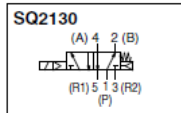
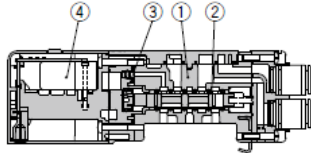

**Rubber seal type**  
Single: SQ2131

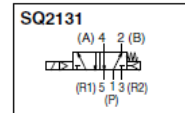
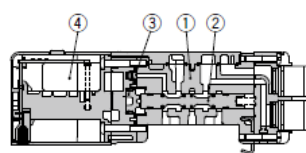

**Double: SQ2230D**

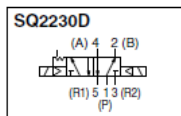
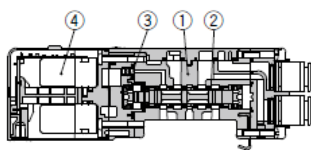

**Double: SQ2231D**

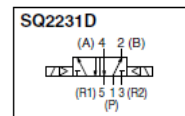
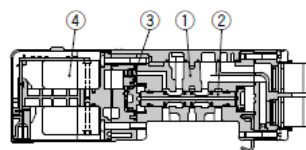

**3 position: SQ2430**

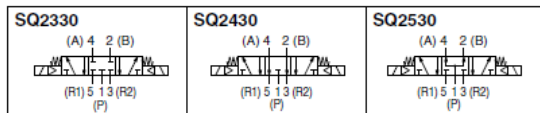
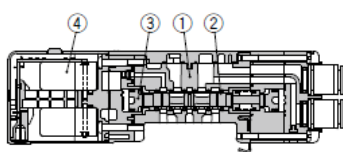

**3 position: SQ2431**

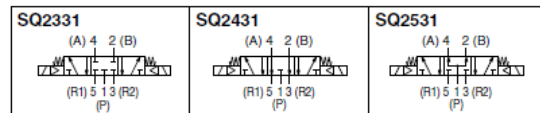
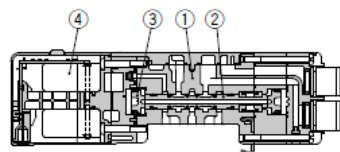

### Component Parts

No.	Description	Material
1	Body	Aluminum die-casted
2	Spool/Sleeve	Stainless steel (Metal seal)
	Spool	Aluminum (Rubber seal)
3	Piston	Resin
4	Pilot valve assembly (Refer to the below.)	—

### Pilot valve assembly

V112 □ - □

• **Coil voltage**

5	24 VDC
6	12 VDC

• **Function**

Symbol	Specifications	DC
Nil	Standard type	(0.4 W)
B	Quick response type	(0.95 W)

Note) Common to single solenoid and double solenoid

**Dual 3 port valve: SQ2B31**

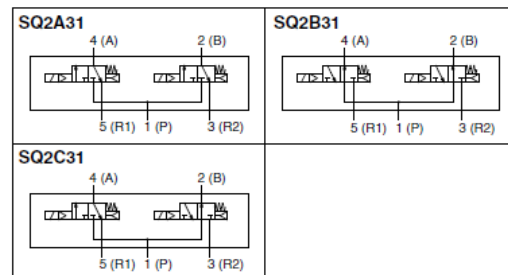
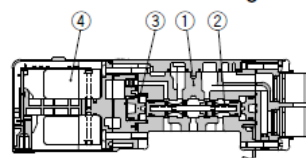

# SQ1000 Series

## Construction: SQ1000 Series Plug Lead Type Main Parts and Pilot Valve Assembly

### Metal seal type

Single: SQ1140

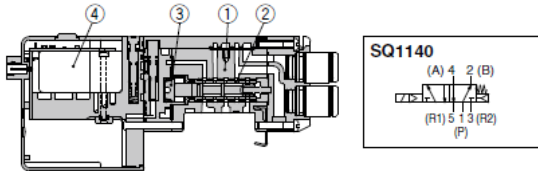

Double: SQ1240D

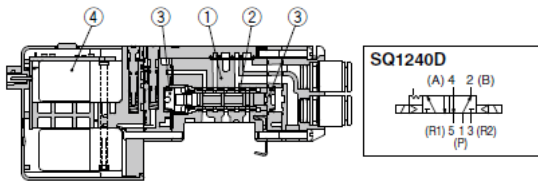

3 position: SQ1440

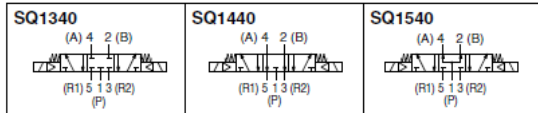
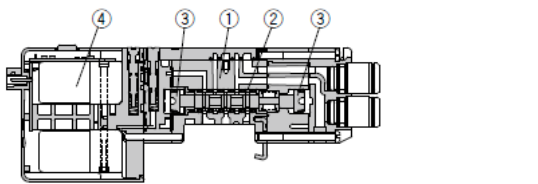

### Rubber seal type

Single: SQ1141

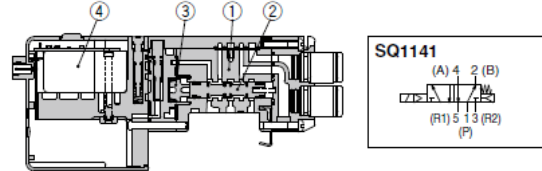

Double: SQ1241D

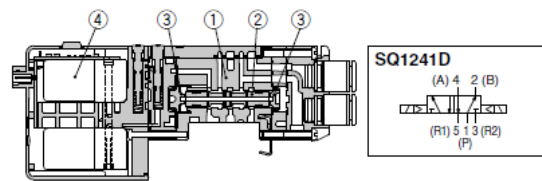

3 position: SQ1441

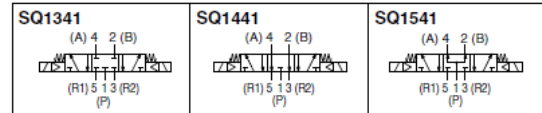
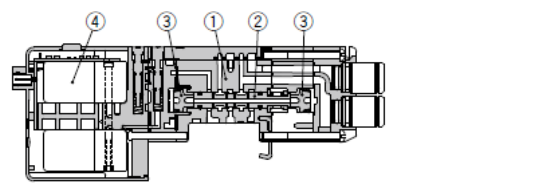

Dual 3 port valve: SQ1641

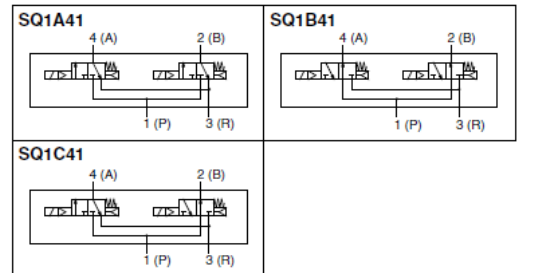
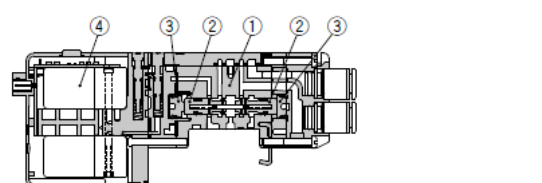

### Component Parts

No.	Description	Material
1	Body	Zinc die-casted
2	Spool/Sleeve	Stainless steel (Metal seal)
	Spool	Aluminum (Rubber seal)
3	Piston	Resin
4	Pilot valve assembly (Refer to the below.)	—

### Pilot valve assembly

V112 □ - □

#### Coil voltage

5	24 VDC
6	12 VDC

#### Function

Symbol	Specifications	DC
Nil	Standard type	(0.4 W) ○
B	Quick response type	(0.95 W) ○
K	High pressure type (1.0 MPa)	(0.95 W) ○

Note) Common to single solenoid and double solenoid



# Plug Lead Unit **SQ2000 Series**

## Construction: SQ2000 Series Plug Lead Type Main Parts and Pilot Valve Assembly

### Metal seal type

Single: SQ2140

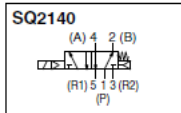
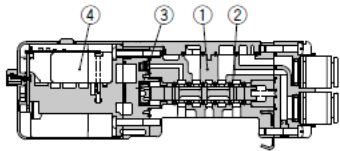

### Rubber seal type

Single: SQ2141

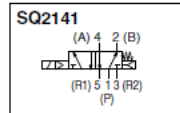
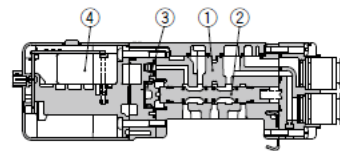

Double: SQ2240D

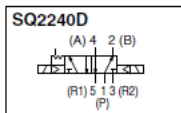
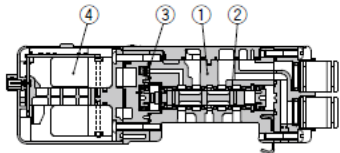

Double: SQ2241D

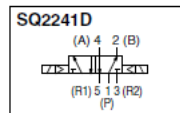
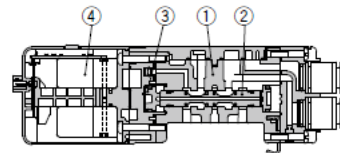

3 position: SQ2440<sup>3/5</sup>

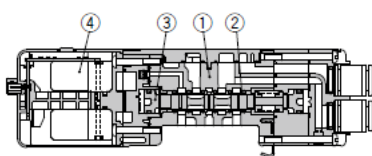

3 position: SQ2441<sup>3/5</sup>

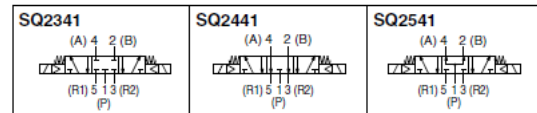
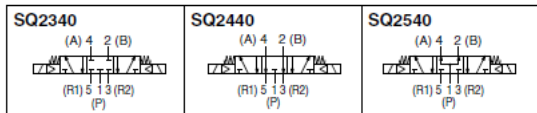
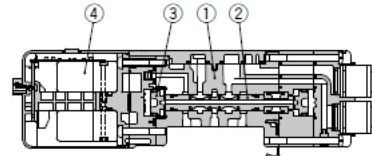

### Component Parts

No.	Description	Material
1	Body	Aluminum die-casted
2	Spool/Sleeve	Stainless steel (Metal seal) Aluminum (Rubber seal)
3	Piston	Resin
4	Pilot valve assembly (Refer to the below.)	—

### Pilot valve assembly

V112 □ - □

#### Coil voltage

5	24 VDC
6	12 VDC

#### Function

Symbol	Specifications	DC
Nil	Standard type	(0.4 W) ○
B	Quick response type	(0.95 W) ○

Note) Common to single solenoid and double solenoid

Dual 3 port valve: SQ2B41<sup>A/C</sup>

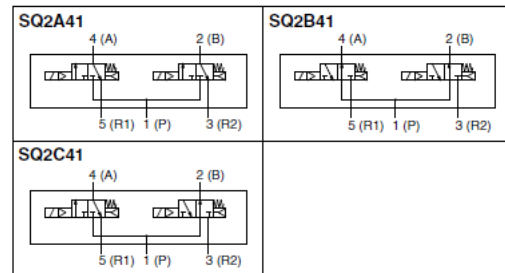
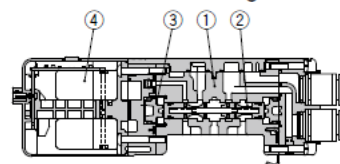



Problem	For valve failure, take following countermeasure referring to Problem.	Possible causes	Countermeasures
Operation failure  Air is not switched.	<pre> graph TD     Q1{The valve operate when the manual override button is pushed?}     Q2{Indicator LED turns on when the valve is energized?}     C1[1) Sliding failure or sticking of the main valve Foreign matter coming from the air source is caught in the main valve, causing sliding failure or sticking.]     C2[2) Decreased pressure Air source pressure is reduced and minimum operating pressure of the valve was not reached.]     C3[1) Non-conformance of electric system • Incorrect wiring • Fuse blown out, breakage of lead wire • Incorrect contact at the contact and connection • Sequencer non-conformance • Supply voltage insufficient]     C4[1) Drop of supply voltage Even if the indicator LED turns on, the valve may not operate due to voltage drop.]     C5[2) Leakage current The valve does not switch due to the residual voltage when OFF.]     C6[3) Failure of the installed pilot valve • Pilot valve coil breakage • Foreign matter is caught in the pilot valve armature. • Swelling of the pilot valve poppet • Pilot valve coil burnt (High voltage, difference of the coil specifications, entry of water)]          Q1 -- NO --&gt; C1     Q1 -- YES --&gt; Q2     Q2 -- NO --&gt; C3     Q2 -- YES --&gt; C4     C4 --&gt; C5     C5 --&gt; C6           </pre>	1) Sliding failure or sticking of the main valve Foreign matter coming from the air source is caught in the main valve, causing sliding failure or sticking.	<ul style="list-style-type: none"> <li>• Replace the valve.</li> <li>• Purify the air source.</li> </ul>
	2) Decreased pressure Air source pressure is reduced and minimum operating pressure of the valve was not reached.	<ul style="list-style-type: none"> <li>• Adjust the pressure within the specification range for the valve.</li> </ul>	
	1) Non-conformance of electric system <ul style="list-style-type: none"> <li>• Incorrect wiring</li> <li>• Fuse blown out, breakage of lead wire</li> <li>• Incorrect contact at the contact and connection</li> <li>• Sequencer non-conformance</li> <li>• Supply voltage insufficient</li> </ul>	Check all possible causes and make sure the wiring is correct. Replace the part, if necessary.	
	1) Drop of supply voltage Even if the indicator LED turns on, the valve may not operate due to voltage drop.	<ul style="list-style-type: none"> <li>• Check the supply voltage. Take corrective action if voltage drop is confirmed.</li> </ul>	
	2) Leakage current The valve does not switch due to the residual voltage when OFF.  3) Failure of the installed pilot valve <ul style="list-style-type: none"> <li>• Pilot valve coil breakage</li> <li>• Foreign matter is caught in the pilot valve armature.</li> <li>• Swelling of the pilot valve poppet</li> <li>• Pilot valve coil burnt (High voltage, difference of the coil specifications, entry of water)</li> </ul>	<ul style="list-style-type: none"> <li>• Check the residual voltage. Keep the residual voltage at 3% of the rated voltage (DC coil) or less.</li> <li>• Replace the pilot valve assembly.</li> <li>• Clean the air supply</li> <li>• Check the voltage, and replace the pilot valve assembly.</li> <li>• Protect the valve, especially the coil to prevent being exposed to water.</li> </ul>	
Response failure  Slow response		1) Leakage current Response delayed due to the residual voltage when the valve is off.  2) Clogging of manifold filter element  3) Sliding failure or sticking of the main valve. Foreign matter coming from the air source is caught in the main valve, causing sliding failure or sticking.	<ul style="list-style-type: none"> <li>• Check the residual voltage. Keep the residual voltage at 3% of the rated voltage (DC coil) or less.</li> <li>• Clean the element or replace it.</li> <li>• Replace the valve.</li> <li>• Clean the air supply</li> </ul>
Air leakage	<div style="border: 1px solid black; padding: 5px; width: fit-content; margin-bottom: 10px;">             Check the air leakage point           </div> 1. Leakage between the valve and base	1-1) Valve mounting screw is loose  1-2) Gasket is caught 1-3) Foreign matter is caught	Make sure that the gasket of the valve mounting surface is not displaced or deformed before tightening. Appropriate tightening torque <ul style="list-style-type: none"> <li>• SQ1000 : 0.17 to 0.23N · m</li> <li>• SQ2000 : 0.25 to 0.35N · m</li> </ul> If gasket is scratched, replace the gasket. Replace the gasket. Eliminate foreign matter with air blow. If gasket is scratched, replace the gasket.

Problem	For valve failure, take following countermeasure referring to Problem.	Possible causes	Countermeasures
Air leakage	2. Air leaks from the One-touch fitting.	2-1) Tube is not inserted all the way into the fitting. 2-2) Tube has a gouge 2-3) The cut surface of the tube is slanted.	Check all possible causes and make sure the piping is correct. Replace the part, if necessary.
		2-4) One-touch fitting seal is damaged	Replace One-touch fitting assembly
	3. Air leakage from the exhaust (R) port. Note) Metal seal type has approximately 200cc of leakage per valve set. This is within specification value. (Supply pressure: 0.5 MPa)	3-1) Internal leakage increased because foreign matter coming from the air source is caught in the main valve.	<ul style="list-style-type: none"> <li>• Replace the valve.</li> <li>• Purify the air source.</li> </ul>
	4. Air leaks from the manifold	4-1) Loose DIN rail clamp screw	Hold manifolds tightly for tightening so that there is no gap between the valves. Appropriate tightening torque 0.8 to 1.0N · m

Revision history

▣	Safety Instructions	
	Precautions	
	Specific Product Precautions	
	Valve construction	WS

1st Printing :RP

## SMC Corporation

4-14-1, Sotokanda, Chiyoda-ku, Tokyo 101-0021 JAPAN

Tel: + 81 3 5207 8249 Fax: +81 3 5298 5362

URL <http://www.smcworld.com>

---

Note: Specifications are subject to change without prior notice and any obligation on the part of the manufacturer.

© 2018 SMC Corporation All Rights Reserved